

1 Introduced June 23, 2015, by Councilwoman  
2 Harbison, seconded by Councilman Borchert,  
3 (by request of Administration)

4 **Item No. 15-06-3104**

5 **ORDINANCE NO. 3785**

6 An ordinance amending the Code of Ordinances of the City of Slidell,  
7 Appendix B, Subdivision Regulations, Sec. 4-5. Sidewalks.

8 WHEREAS, the Slidell City Council has received a request from the Planning  
9 Department to amend the current sidewalk design regulations; and

10 WHEREAS, the purpose of the amendment is to update sidewalk design  
11 standards to meet current American with Disability Act (ADA) requirements.

12 NOW THEREFORE BE IT ORDAINED by the Slidell City Council that it  
13 hereby amends the Code of Ordinances of the City of Slidell, Appendix B, Subdivision  
14 Regulations, Sec. 4-5 Regulations, Sec. 4-5. Sidewalks, by deleting the entire paragraph  
15 under Section 4.5. Sidewalks and replace with the following:

16 **4.501. Sidewalk Regulation.**

17 Sidewalks shall be constructed in all subdivisions and at all building sites with the  
18 following exceptions:

- 19 (1) Sidewalks are not required in residential neighborhoods if there is not an  
20 existing sidewalk within 300 feet on the same side of the street.
- 21 (2) Along State Highways the developer must submit a permit for construction of  
22 sidewalks to the Louisiana Department of Transportation and Development  
23 Section 62 (LA DOTD) for approval. If the LA DOTD Section 62 denies the  
24 permit then sidewalks are not required.
- 25 (3) If street is in a St. Tammany Parish public right of way a permit must be  
26 submitted to St. Tammany Parish Engineering Department for approval. If St.  
27 Tammany Parish Engineering denies the permit then sidewalks will not be  
28 required.
- 29  
30  
31  
32  
33  
34  
35  
36  
37  
38  
39

4  
5 4.502. Sidewalk Definitions.

6  
7 The following definitions are provided for sidewalk design:

- 8 (1) *Curb*: Raised or vertical element that provides any or all of the following  
9 purposes: drainage control, roadway edge delineation, right-of-way  
10 reduction, aesthetics, delineation of pedestrian walkways, reduction of  
11 maintenance operations, and assistance in orderly road side development. A  
12 sidewalk may contain the following elements
- 13 (a) *Curb Face*: Side of the curb facing the roadway.
  - 14 (b) *Back of Curb*: The line that delineates the curb from adjoining planting  
15 zone or pedestrian zone.
  - 16 (c) *Barrier Curb/Vertical Curb*: Vertical or nearly vertical curb face  
17 intended to discourage vehicles from leaving the roadway.
  - 18 (d) *Mountable Curb/Sloping Curb*: Low flat sloping faces designed so  
19 vehicles can cross them readily when need arises.
- 20 (2) *Planter Zone*: Area between the back of curb and edge of pedestrian zone or  
21 bicycle zone where street trees, grass, shrubs, and any other vertical public  
22 infrastructure is placed. Minimum width of the planter zone is two feet.
- 23 (3) *Bicycle Zone*: Area set aside for bicycles. Minimum width is five feet for one  
24 way bicycling; 10 feet for two way bicycling.
- 25 (4) *Pedestrian Zone*: Area set aside for pedestrians. Minimum width when there  
26 is a planter zone is five feet. Minimum width when there is not a planter zone  
27 is six feet.
- 28 (5) *Frontage Zone*: Area between edge of the sidewalk and the line separating  
29 the public right-of-way from private property. Minimum width is one foot.
- 30 (6) *Shared Use Path*: A wide sidewalk intended for use by both pedestrians and  
31 bicycles. Minimum width is ten feet.

32  
33 4.503. Sidewalk Design Requirements.

34  
35 Figures 1 through 3 are the City's approved sidewalk designs. Figures 1 and 2  
36 provide a choice for pedestrian only sidewalks. Figure 3 is for shared use paths.

37  
38  
39

1 **ORDINANCE NO. 3785**  
2 **ITEM NO. 15-06-3104**  
3 **PAGE 3**

4 (1) *Pedestrian Only Sidewalks*. The City has two approved pedestrian only  
5 sidewalk designs -- Figures 1 and 2. The differences between the two  
6 designs are the presence or absence of a planter zone, the amount of  
7 standoff between the roadway and the pedestrian zone or bicycle zone, and  
8 curb types allowed.

- 9 • Five foot is the minimum width of the pedestrian zone, because this is  
10 required width for wheelchair use (five foot is minimum diameter for a  
11 wheelchair to turn around).
- 12 • When there is no planter zone the minimum pedestrian zone width is  
13 increased to a minimum of six feet. The additional foot is needed to  
14 separate pedestrians from vehicles using the adjacent roadway.
- 15 • Barrier/Vertical curbs are required when there is no separation  
16 between the roadway and the pedestrian zone or bicycle zone. When  
17 there is a planter zone the curb can be either barrier/vertical or  
18 mountable/sloped.
- 19 • The planter zone must be a minimum of two feet in width to allow  
20 space for maintenance.

21 (a) Option 1: A minimum two foot Planter Zone, and a minimum five foot Pedestrian  
22 Zone (See Figure 1)  
23  
24  
25  
26  
27  
28  
29  
30  
31  
32  
33  
34  
35  
36  
37  
38  
39

4 **Figure 1: Pedestrian Sidewalk with Planter Zone**

5 1. Five foot Pedestrian Zone with two foot Planer Zone

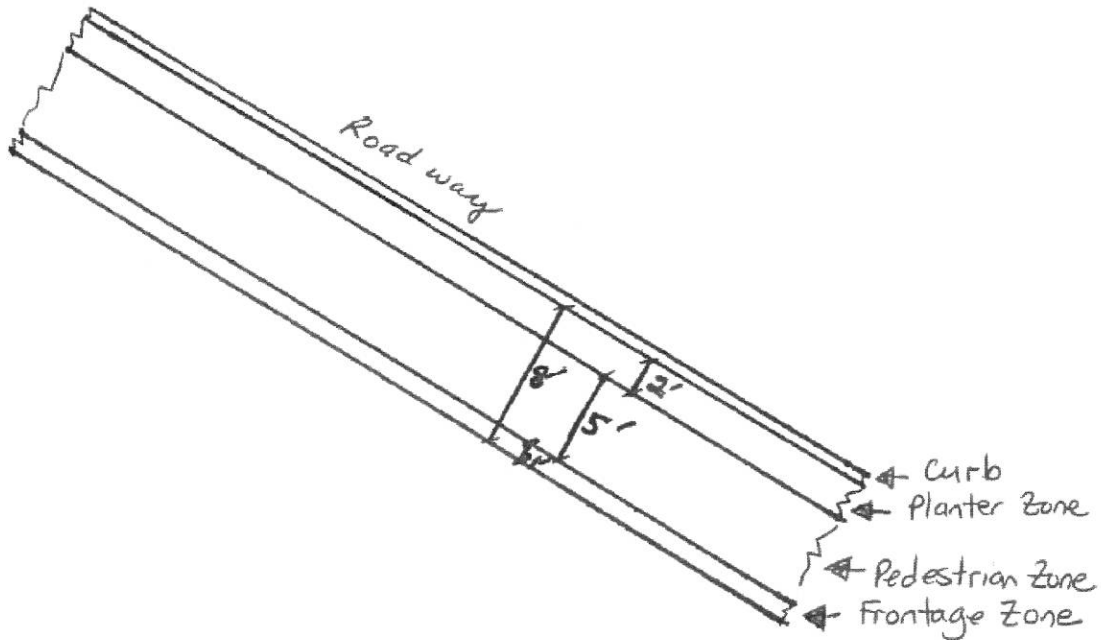

- 22 Curb: Barrier or mountable, barrier preferred
- 23 Planter Zone: Two foot minimum
- 24 Bicycle Zone: None
- 25 Pedestrian Zone: Five foot minimum
- 26 Frontage zone: One foot minimum

4 (b) Option 2: No Planter Zone, and a minimum six foot Pedestrian Zone.

5  
6 **Figure 2: Pedestrian Sidewalk without Planter Zone**

7 **2. Six foot Pedestrian Zone with no Planter Zone**

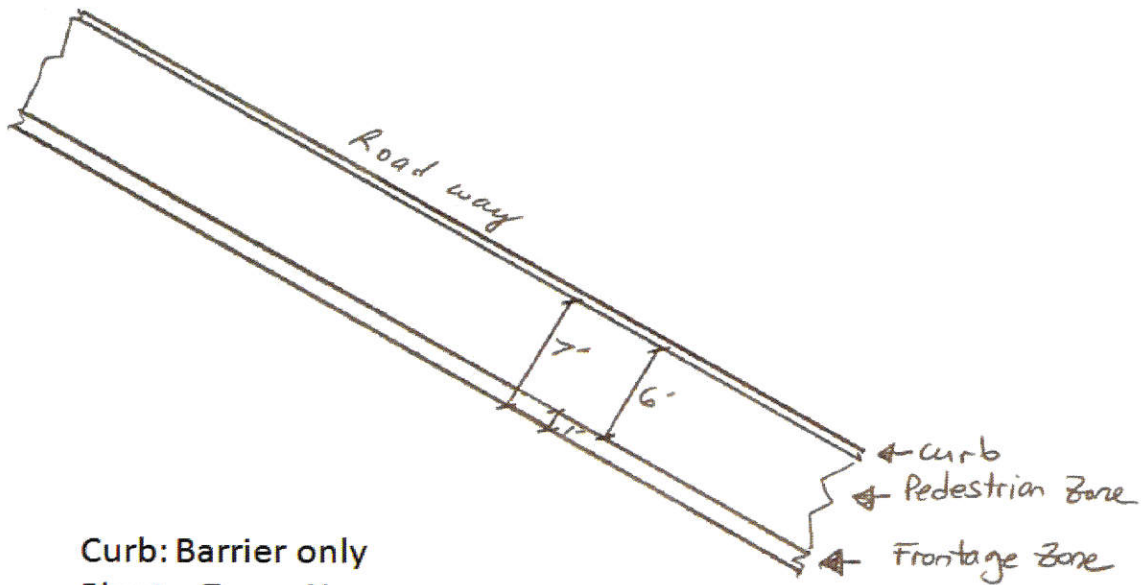

- 23 Curb: Barrier only
  - 24 Planter Zone: None
  - 25 Bicycle Zone: None
  - 26 Pedestrian Zone: Six foot minimum
  - 27 Frontage zone: One foot minimum
- 28  
29  
30  
31  
32  
33  
34  
35  
36  
37  
38  
39

4 (2) *Shared Use Path*. The Shared Use path is intended to accommodate both  
5 pedestrian and bicycles. The minimum width is ten feet broken into two five  
6 foot wide lanes, one in each direction. The divider can be delineated by paint  
7 alone. If there is a raised surface its width must be added to the minimum 10'  
8 path width to accommodate wheel chair use. Raised surface is defined as any  
9 vertical change that would impede the free movement of a wheel chair.

10  
11 **Figure 3: Shared Use Path**

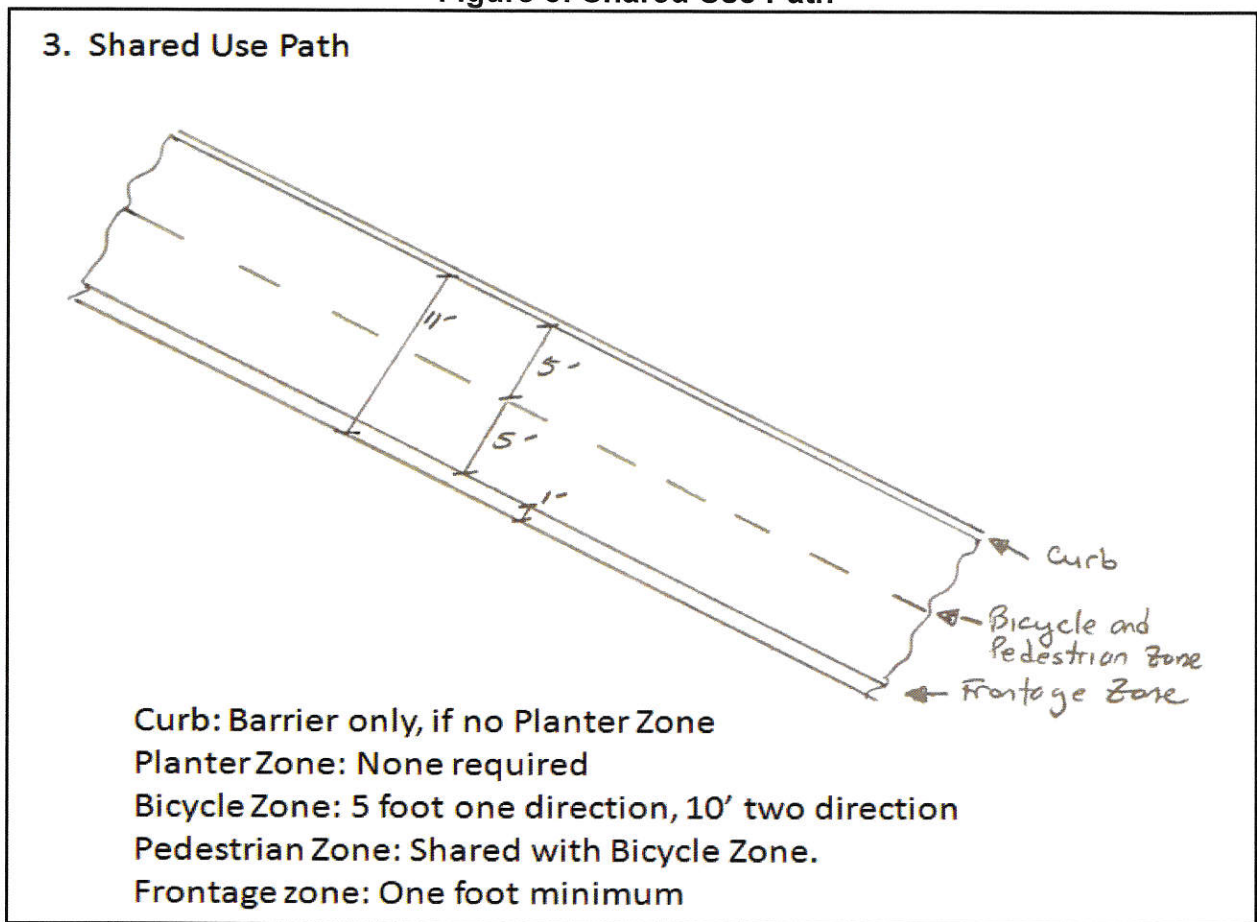

33 (3) *Other requirements*

34  
35 (a) Sidewalks will be constructed of 4 inch thick concrete. Additional  
36 technical specifications for constructing sidewalks are provided in  
37  
38  
39



4 Appendix B.1- Standard: Subdivision Regulations, Division II:  
5 Technical Provisions,

- 6 • Section 1 - Streets; Paragraph 4.0 - Concrete Pavement
- 7 • Section 3 - Concrete Driveways and Sidewalks

8 (b) Sidewalks will be free of obstruction. Where sidewalks must shift to  
9 avoid obstructions the shift will be gradual so that pedestrians and  
10 bicyclists have ample time to adjust.

11 (c) Sidewalk grade will not exceed 5.0 percent.

12 (d) Sidewalk cross slope will not exceed 2.0 percent.

13 (e) Whenever a sidewalk transitions to street level or a driveway crossing  
14 the connection will be smooth so as to not provide a trip hazard.

15 (f) Use Louisiana Department of Transportation standard plans for curb  
16 ramps, sidewalk pedestrian facilities, intersection layouts, and  
17 detectable warnings.

18 (4) Special Designed Sidewalks. City of Slidell will approve special designed  
19 sidewalks to accommodate unique location restrictions on a case-by-case  
20 basis. Examples of unique location restrictions include but are not limited to  
21 lack of sufficient public right-of-way, less than 7' available from back of curb  
22 to property line, and other public infrastructure is obstructing the area  
23 available for sidewalks. Submit request, with design specifications, to the  
24 City Planning Department. The Planning Department will staff the request to  
25 the Engineering Department and Public Operations Department. Based on  
26 the three departments' input, the plan will be approved, approved with  
27 modifications, or denied. The Planning Department will notify the  
28 owner/developer/contractor of the City's decision.

29 (5) Distances provided are minimums. City encourages developer/property  
30 owner/contractor to provide wider sidewalks when practical, especially in  
31 high pedestrian traffic areas.

4  
5  
6  
7 **ADOPTED** this 28th day of July, 2015.

8  
9 

10 Bill Borchert  
11 President of the Council  
12 Councilman, District G

13  
14 

15 Freddy Drennan  
16 Mayor

17  
18 

19 Thomas P. Reeves  
20 Council Administrator

21  
22  
23  
24  
25  
26  
27  
28  
29  
30  
31  
32  
33  
34  
35  
36  
37  
38  
39

DELIVERED	7/29/15
	11:40 a.m. to the Mayor
RECEIVED	7/30/15
	2:45 p.m. from the Mayor